

Clevertest Plus

Refer to the supplementary operation guide supplied with the Product.
After Power ON, the Status LED on a Clevertest Plus enabled fitting will display a rapid Green or Red flashing for a period up to 2 minutes.

Zoneworks, HIVE and DATA Monitored Options

Fittings with part numbers -ZW, -HV/-HVG, -DATA are fitted with Zoneworks communications modules (nodes). These fittings are monitored using either Powerline Carrier Technology that utilize the power cable to provide data communication, RF transceiver modules operating in the ISM band or a dedicated data cable to/from data routers installed on a dedicated data trunk connected to a central Server (can also be connected via Ethernet/Internet/Fibre). Zoneworks software on the server is used to monitor, coordinate testing and collate test data from each fitting. Zoneworks Fittings can be commissioned by a single push of the test switch or by scanning the supplied barcode. The LED Test Switch indicator provides a multifunction indication of the status of the fitting during testing and normal operation:

Option	State	LED Operation
ZW, HV, HVG, DATA	Commissioned	LED on Solid (Green)
ZW, DATA	Un-commissioned	Batt plugged-in: yellow 1s, green 1s
		Batt unplugged: red 1s, off 1s
HV, HVG	Un-commissioned With network connectivity	Batt plugged-in: yellow 1s, green 1s
		Batt unplugged: red 1s, off 1s
HV, HVG	Un-commissioned Without network connectivity	Batt plugged-in: yellow 250mS, green 250mS, yellow 250mS, green 250mS, green 1s
		Batt unplugged: red 250mS, off 250mS, red 250mS, off 250mS, off 1s
ZW, DATA	Emergency Light Test In Progress	LED flashes at yellow 5s , Off 1s
HV, HVG	Emergency Light Test In Progress	LED flashes at yellow 1s , Off 1s

In the case of the DATA version a 2-way "figure 8" cable and terminal block facilitates the connection to the DATA network via a multi-drop bus (daisy chain connection). For further information of installation of a Zoneworks system, please refer to the Zoneworks Users Guide and Commissioning Guide (incl. DATA version)

DALI 2 EM Option

Luminaires with part numbers having -D2 are fitted with DALI 2 certified modules (nodes) that facilitate connection and integration to 3rd Party Lighting Control Systems. Before installing the fitting please confirm that the Lighting Control System has the capability to monitor DALI Emergency Luminaires. The fitting will be addressed and configured into the control system by the Lighting Control System Commissioning Technicians and not Clevertronics

State	LED Operation
Commissioned/ Un-commissioned	LED on Solid (Green)
Emergency Light Test in progress	LED flashes at 1s On (Yellow) & 1s Off
"IDENTIFY COMMAND"	Lamp and Status LED Flash for 30 seconds

A 2-way "figure 8" cable and terminal block facilitates the connection to the DALI network OR a 5/6way "structured wiring system" lead and plug facilitating the power and DALI connection. DALI connections are marked as Da Da.

Testing: Once connected to the 240V mains supply, the unit must be allowed to charge the battery for at least 24 hours. Conduct the following tests:

- For the first test, the emergency lamp must remain illuminated for at least 2 hours after disconnection from the mains supply.
- Subsequent tests require the unit to illuminate for at least 90 minutes. The results of all tests are required to be recorded in a service logbook, which is to be always kept on-site. If the unit fails to remain illuminated for the requisite time, remedial action must be taken to repair the situation and once completed, the unit must pass a subsequent test. For more specific information, please refer to the current edition of the AS/NZS 2293.2 and AS/NZS 60598.2.22 Standards.



L10™ Weatherproof Jumbo LED Exit One Box Solution

Installation & Maintenance Instruction Leaflet



Dimensions: 570mm x 117mm x 340mm Weight 5.6KG

NOTE: Standard product codes with this symbol  are enabled with Clevertest Plus capability. Please refer to the operation guide supplied with the product for details.

Models: LJWELED-40-xx-yy-uu-ww-zz-vv

Testing:

Manual Test xx = Blank
Zoneworks xx = ZW

Z/W DATA xx = DATA
Zoneworks HIVE xx = HV/HVG
DALI Registered. xx = DALI
DALI-2 xx = D2

Spare Parts:

1530030 Replacement Battery
1530231 Replacement Battery (-4HR)
AUM01370050001 Replacement Emergency Driver
8050640 Replacement Emergency LED

Important:

It is illegal for anyone, except for a licensed electrician to install or maintain this product. Before installation, ensure that the electricity supply has been switched off and isolated. Installation must be carried out in accordance with the relevant Australian and International Standards.

Caution:

On many building sites, power circuits may be cut off in an uncontrolled and repetitive basis during construction. As a result, any Exit & Emergency Units, on these circuits, will have their batteries discharged or "cycled". The Li-ion battery in this fitting has been selected to give excellent long-life performance in a controlled AS 60598.2.22 testing environment. Excessive battery cycling will reduce through-life performance and may lead to premature battery failure. Battery warranty claims, as a result of such abuse, are specifically EXCLUDED from Clevertronics warranty terms.

Victoria (Head Office & Manufacturing)
Website: www.clevertronics.com.au
Email: info@clevertronics.com.au
Phone: +61 3 9559 2700

New South Wales
Phone: +61 2 8805 6400

Queensland
Phone: +61 7 3442 9700

South Australia/Northern Territory
Phone: +61 8 8301 8800

Western Australia
Phone: +61 8 9207 0000

New Zealand
Phone: +64 800 548 448

Options:

Tamperproof yy = TP
Uninterrupted Power Supply ww = UPS
Black Colour uu = BLK
Special zz = SP
4 Hour Battery vv=4HR

Installation:

- Locate the installation position.
- Remove the front trim piece, by levering one of the corners up and pulling off. (Figure A)
- Remove the front Diffuser by undoing the 4 holding screws then lever it out. (Figure A)
- Remove Gear Tray by undoing the 3 retaining screws using a suitable screwdriver. (Figure B)
- Position the product in the wall or ceiling mount position & pre-drill mounting holes (Figure C).
- Wall Mount pull back the Seal Tab to expose mounting holes. Feed your screwdriver through front facing holes to access fixing screws (Figure C).
- Mount product using suitable fixings (including consideration of maintaining the IP rating).
- Drill suitable entry points for supply cables either on the top, rear, or sides of the base using a suitable tool for polycarbonate plastic. (Figure C)
- The product is designed to take a Maximum M25 Cable Gland/ conduit adaptor. A suitable round cable diameter will need to be selected when Cable Gland used, consult Manufacturer datasheet.
- Seal Cable entry and Mounting holes appropriately to maintain the IP Rating stated on the Technical Label.
- Terminate the supply cables to the unswitched Live, Neutral & Earth terminals (in the case of the – DALI or –DATA fittings terminate the cable to the polarity free terminals marked Da Da or DATA).
- Ensure the Battery is connected. Push the gear tray back into position, make sure that the clips on the back are properly engaged, and secure in place using the three screws.
- Attach the diffuser panel by inserting the base into the channel on the body of the exit sign, taking care to verify the seal is in place and the clips are properly engaged, and then fold the panel up to position the locking screws. Tighten the diffuser screws and fit the front trim. (All screws need to be done firm before the front trim can be fitted.)

If the CTP self-test capabilities are activated, please affix the CTP status label to a visible surface and add the letter "F" to the 3rd square in the Four Segment Marking on the product

Note:

This luminaire (with reinforced insulation between control/LED terminal and AC supply) contains non-user replaceable light source and battery - to be replaced (if required, refer installation instructions for battery replacement) by Clevertronics service personnel/agents or a registered electrician.

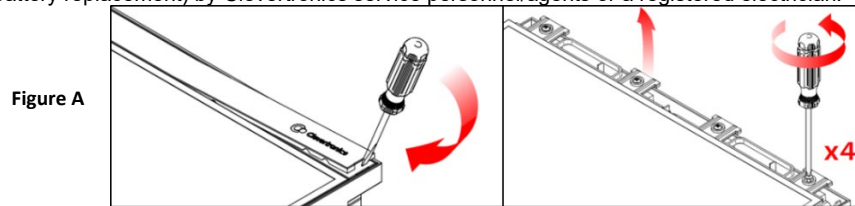

Figure A

Remove Top Trim

Remove Diffuser

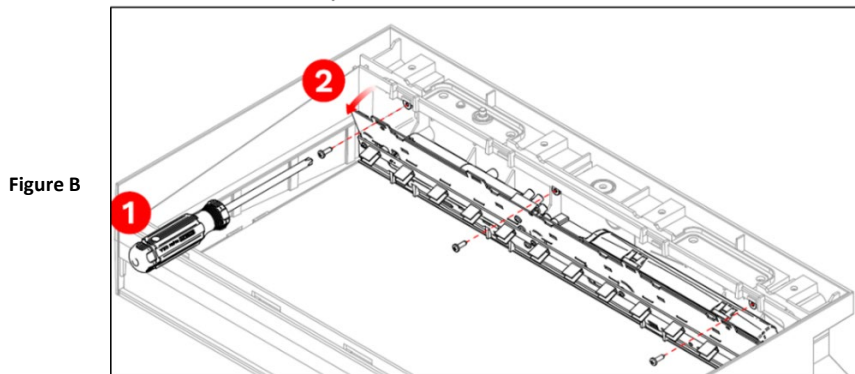
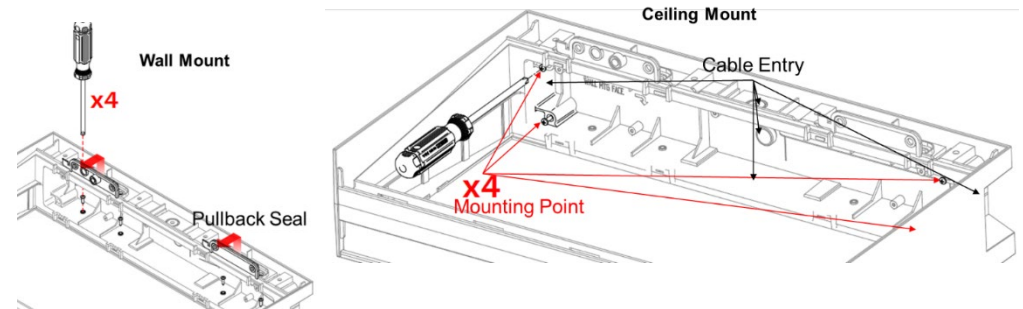
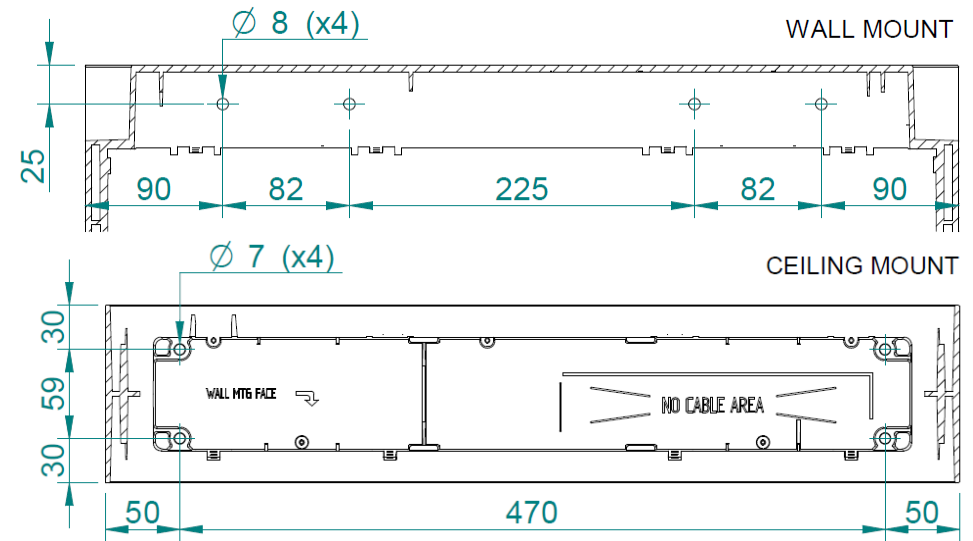

Figure B

Remove Gear tray



Trouble Shooting:

Below are a list of common problems and their possible causes.

Fault: The Green LED Test Switch indicator is not illuminated.

Check: A.C. is connected and is turned on.
Battery is connected
Test Switch for damage.

Fault: Lamp does not illuminate in emergency mode.

Check: A.C. is connected.
Lamp is correctly inserted.
Battery is connected

Fault: Lamp illuminates in emergency mode, but only stays on for a short period.

Check: Battery has been allowed to charge for at least 24 hours.
Battery for damage.

Rated Emergency Lumen Output in accordance with AS2293.1: 2018

Refer to the Technical Label for classification information.

Warranty:

For Product Warranty information and Terms and Conditions of Sales please refer to our website <http://clevertronics.com.au/terms-conditions-sale-australia-nz/>